

THIS DRAWING IS UNPUBLISHED. RELEASED FOR PUBLICATION
 © COPYRIGHT BY TYCO ELECTRONICS CORPORATION. ALL RIGHTS RESERVED.

LOC	DIST	REVISIONS					
AF	50	P	LTR	DESCRIPTION	DATE	DWN	APVD
		D1		REVISED PER ECR-07-014644	27JUN07	HMR	GJ

- 1 SPECIFICATIONS:
MAGNET WIRE #18- #34 AWG
.040" (1.02 mm)- .006" (0.16 mm) DIA COPPER.
- 2 POCKET RECOMMENDATION: #1601431
- 3 TERMINAL APPLICATION TO COMPLY WITH TYCO ELECTRONICS SPECIFICATION 114-13166 FIGURE 10.
- 4 PRELIMINARY - NOT FOR PREPRODUCTION

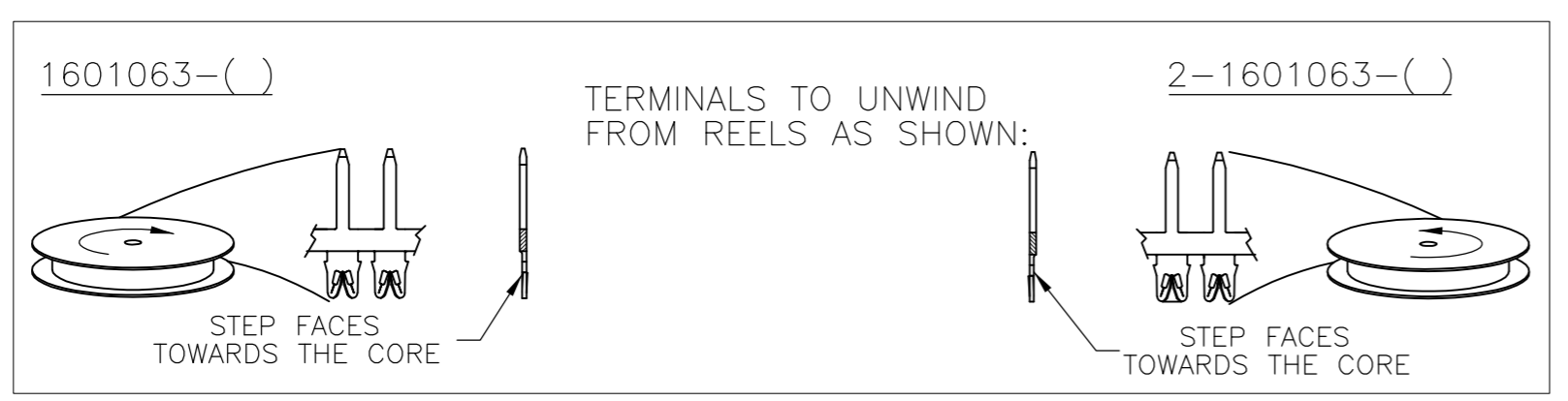
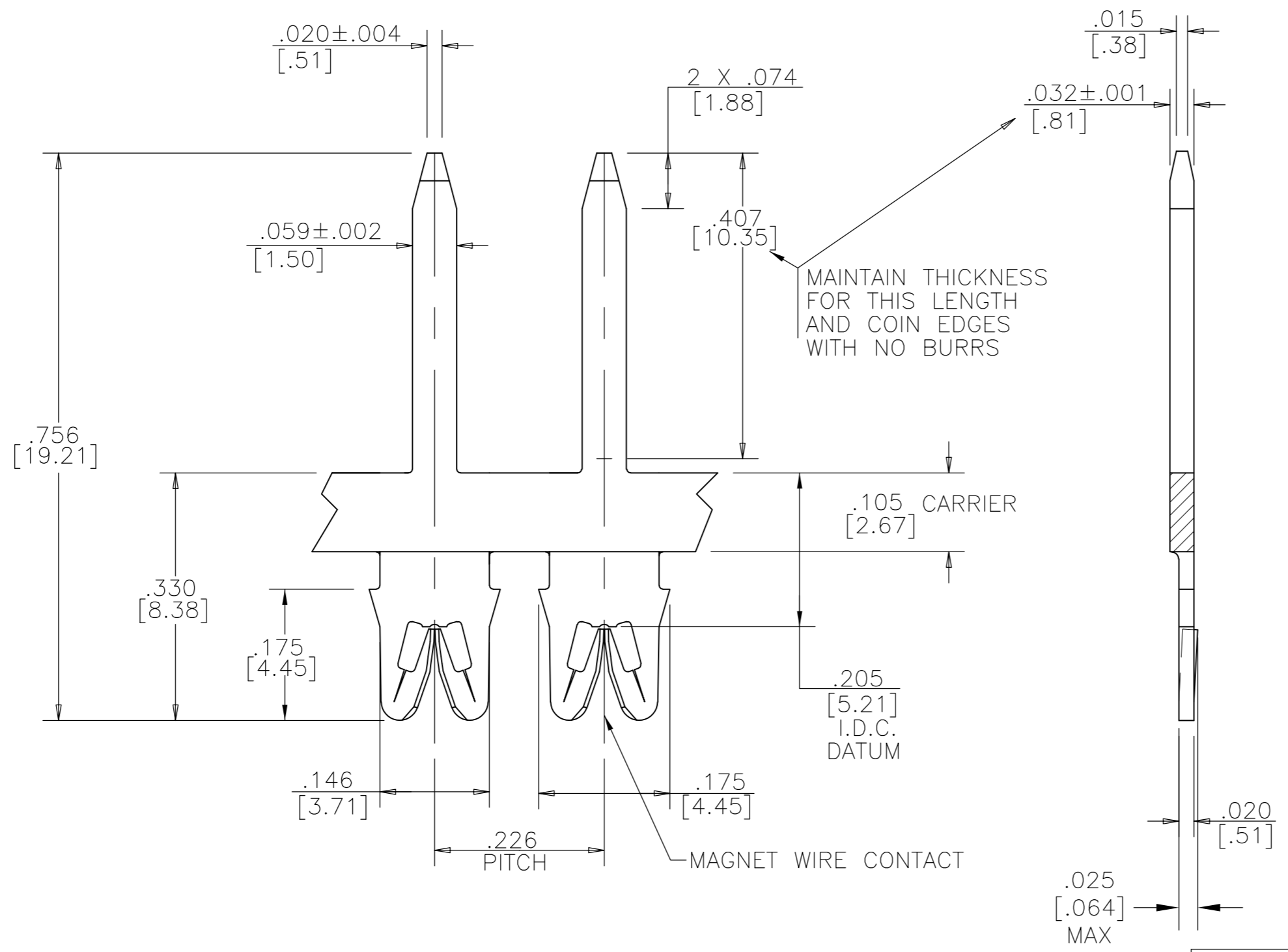

	POST TIN OVER NICKEL		4-1601063-3	
	POST TIN OVER NICKEL		1601063-3	
	PRE TIN PLATE	031-129-021	4-1601063-2	
	PRE TIN PLATE	131-130-021	2-1601063-2	
	PRE TIN PLATE	131-129-021	1601063-2	
	FINISH	REFERENCE PART NUMBER	TYCO PART NUMBER	
THIS DRAWING IS A CONTROLLED DOCUMENT.		DWN J.WELLER 11JAN2002	Tyco Electronics Corporation Harrisburg, Pa 17105-3608	
DIMENSIONS: INCHES		CHK M.FEHER 11JAN2002	NAME	
TOLERANCES UNLESS OTHERWISE SPECIFIED:		APVD K.RANDOLPH 11JAN2002	STANDARD RANGE WIRE TO .059 X .032 TAB SIAMEZE TERMINAL	
0 PLC ± -		PRODUCT SPEC	SIZE CAGE CODE DRAWING NO RESTRICTED TO	
1 PLC ± -		108-2085	A2 00779 C=1601063	
2 PLC ± .01[0.25]		APPLICATION SPEC	SCALE 6:1 SHEET 1 OF 1 REV D1	
3 PLC ± .005[0.13]				
4 PLC ± -				
ANGLES ± 2°				
MATERIAL BRASS, 3/4 HARD	FINISH SEE TABLE	WEIGHT -		
CUSTOMER DRAWING				